

OMRON[®] TECH NOTE

OMRON ELECTRONICS, INC.

Engineering Services Department
One East Commerce Drive
Schaumburg, IL 60173
Telephone: 847-843-7900
Fax: 847-843-7990

DATE: 02/05/96

Total Pages including
this Cover Page = 02

TO: ALL A.E.'s / ESD PERSONNEL

FROM: JERRY PEREZ

SUBJECT: SENSOR: PARALLEL CONNECTION

ESD has had two situations come up in the last few weeks where users of our Sensors want to connect a Prox (TL-X10Y1) Sensor and a Photoelectric (E3F-DS10Z1) Sensor in parallel. As I mentioned in a previous Tech Note a few years ago - parallel connection of two or more 2-wired prox sensors is definitely not recommended.

When using 3-wired photoelectric sensors connected in parallel - check the current rating across the load to see if a parallel resistor (across the load) may be required to pull-up the load current to the sensor (in the example below the LY2 relay has a very low current rating).

In both application situations, the user wanted to connect their sensor's as shown below:

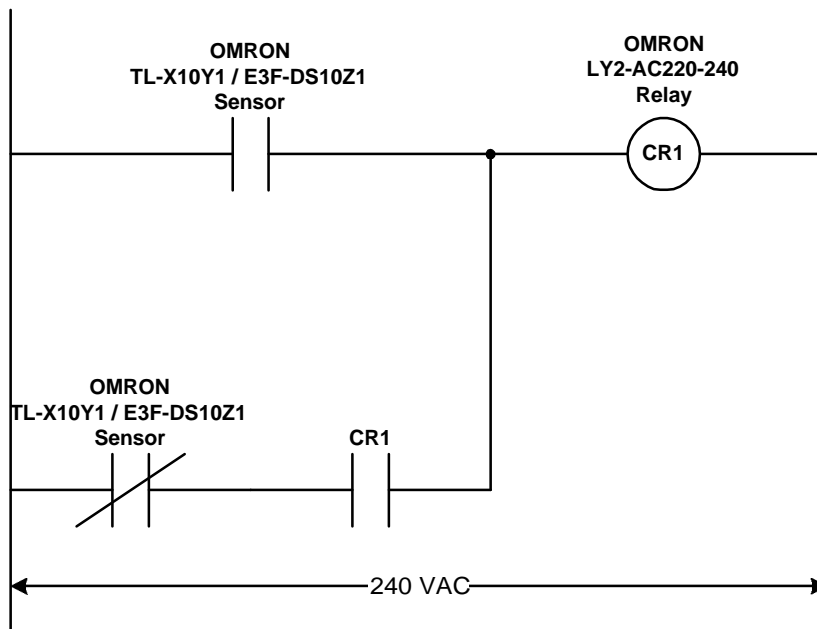

One user was using a prox sensor (TL-X10Y1) and another user was using a photoelectric sensor (E3F-DS10Z1). I had to fax Japan on this because one of the users wanted to hear from the factory that this type of connection was not recommended. I did so, knowing what their answer was going to be.

Japan replied as follows:

“...connecting a TL-X10Y1 in this way is not OK. Please see parallel connection information below for more details.”

“As for the E3F-DS10Z1 Sensor, this is a 3-wired AC Photoelectric Sensor - using this sensor with this type of connection is OK, however, the load current across the relay is much too small. A parallel resistor across the load will be necessary.”

Parallel Connection (2-wired Prox Sensors)

In general, two or more parallel-connected 2-wired proximity switches cannot be used in an OR circuit.

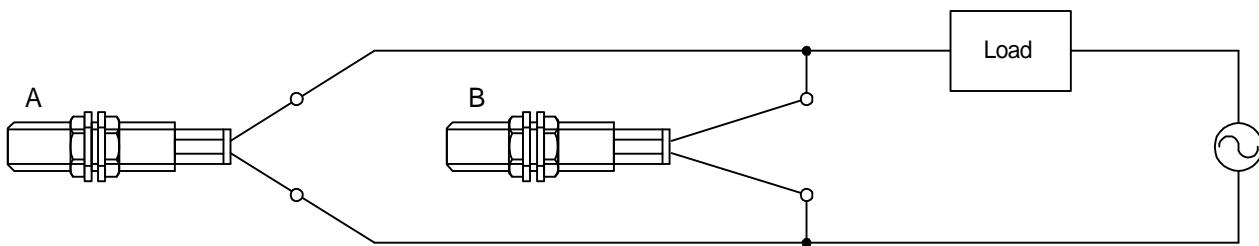

Proximity switches A and B in the above example can be used in parallel connection only when they are not required to operate simultaneously and the load is not required to be held. In this case, however, note that the leakage current increases in proportion to the number of proximity switches connected.

Proximity switches A and B cannot be used in parallel connection when they are required to operate simultaneously to hold the load. Namely, when holding the load by operating switches A and B simultaneously, upon turning ON switch A, the voltage at both ends of switch A (B) drops to approx. 10V and the load current flows through switch A. When the target moves to switch B, since the voltage at both ends of switch B is 10V, the switching element of the switch B may fail to operate due to too low voltage. Upon turning OFF switch A, since the voltage at both ends of switch A (B) rise to the power supply voltage, switch B can turn ON. At this time, there is a moment when both switches A and B are turned OFF (approx. 10ms) and the load is reset momentarily. For this reason, the proximity switches are required to be used through relays to hold the load connected.